



# SAFEPRO ROOFTOP WARNING LINE SYSTEM



Warning Line System is 1.3 psi per base



Bases nest together for easy storage and transportation



Meets OSHA 1910.29(d) design specification



Non-Penetrating design with support pad (sold separately)

## PERMANENT, DURABLE FALL PROTECTION

Permanently secure roof lines with the SafePro Warning Line System. This compact, non-penetrating concrete base design protects your rooftop surface while standing up to the elements for a weather-resistant, long-lasting safety.

### WHY CHOOSE SAFEPRO?

SafePro is an industry-leading provider of safety solutions for workers exposed to fall hazards. We collaborate with building owners, contractors, and architects to design and manufacture fall protection solutions for a variety of applications, in a variety of industries.



### CONTACT US

Phone: (877) 723-3570  
info@safeprosafety.com  
safeprosafety.com

## DETAILS

- Galvanized steel stanchion posts and fittings
- Heavy-duty molded plastic warning flags
- Aluminum top cap set screw secures warning line
- OSHA 1910.29(d) and 1926.502(f)(2) compliant
- Kit Includes 25 feet of plastic-coated steel cable and 4 yellow warning flags

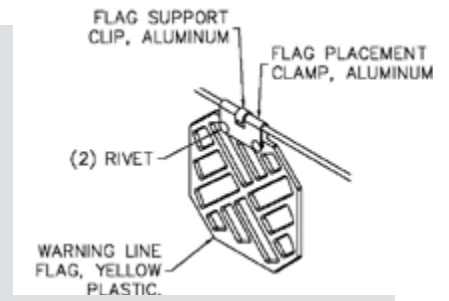

## FAST INSTALLATION

The SafePro Warning Line System installs quickly and securely. Use these simple steps to set up your Warning Line System:

- Install intermediate base plate and stanchion assembly at 24-foot intervals with corner post assemblies and end post assemblies as needed
- Guide cable through each top cap and secure with set screw
- Place warning flags at 6-foot intervals

### Specifications

- Stanchion assembly height: 39"
- Base dimensions: 14" x 14" 4"
- Intermediate base weight : 62 lbs.
- End/Corner base plate weight: 124 lbs.

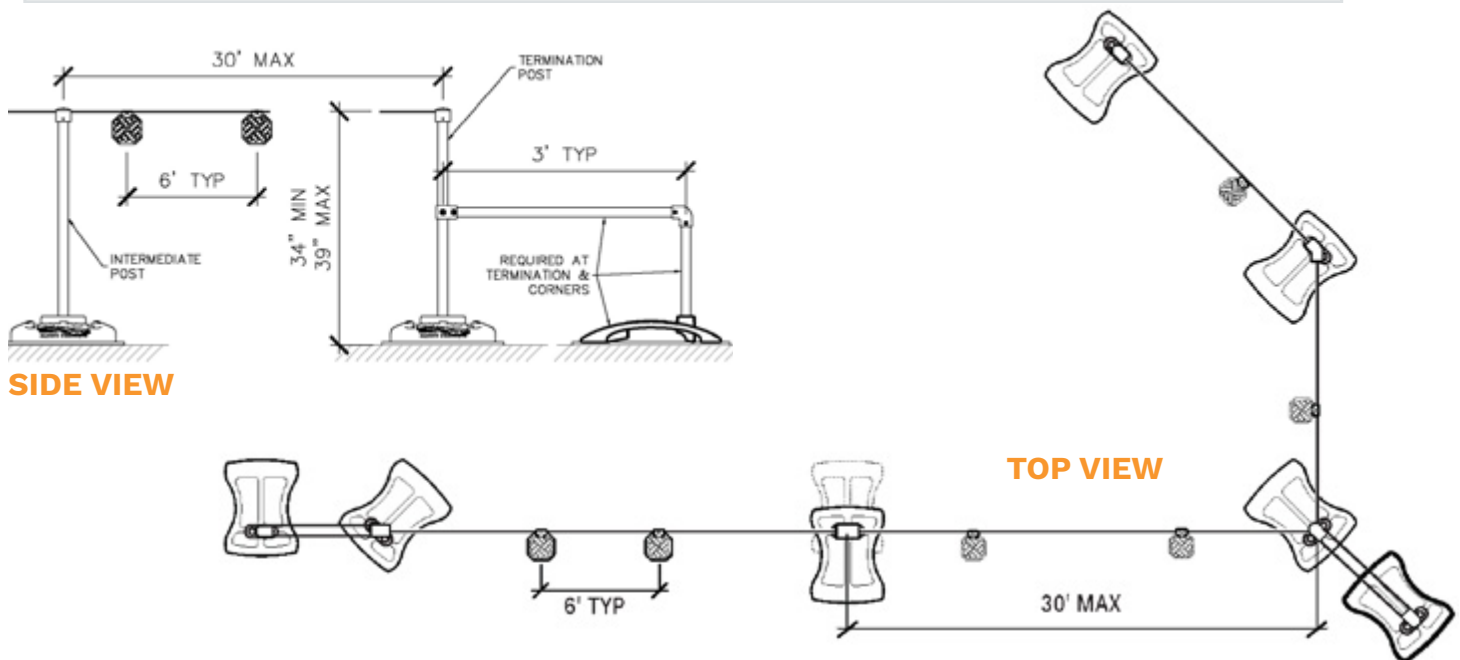

### CONTACT US

Phone: (877) 723-3570  
info@safeprosafety.com  
safeprosafety.com



Scan this code to learn more  
about SafePro Products