



Fall Protection

Bring fall protection along for the ride.

3M™ DBI-SALA® Flexiguard™ Trailer Mounted System

The Trailer Mounted System is a mobile and versatile solution designed to be towed with a service vehicle from application to application. This stand-alone design does not require the service vehicle to be attached for use. With an adjustable anchor height and the capacity for two workers, this solution provides maximum versatility.



Features:

- ▶ System contains two anchor points rated for two users.
- ▶ User weights: 310 lbs. (141 kg) or less.
- ▶ Rated for highway, public road, and off-road use.
- ▶ System designed to be freestanding and does not require the weight of a vehicle for Fall Protection use.
- ▶ System quickly raises and lowers with integrated winch and handle.
- ▶ System includes heavy-duty stabilizing jacks.
- ▶ Integrated brake mechanism automatically locks the mast height in the desired position.
- ▶ Integrated hydraulic surge brakes.
- ▶ High clearance 6k torsion axle.
- ▶ Adjustable height pintle hitch.

Applications:



General industry

- ▶ Construction



Transportation

- ▶ Aviation



Mining

- ▶ Heavy equipment maintenance

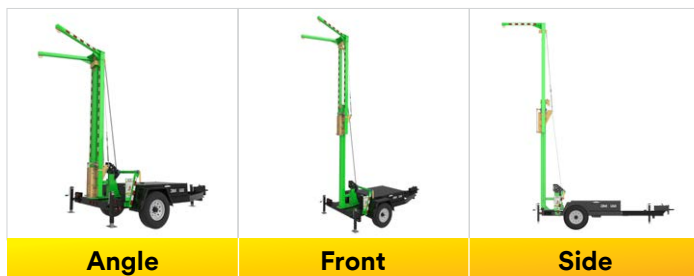

Conforms to the requirements of 29 CFR OSHA 1910.140 | 29 CFR OSHA 1926.502

For use in Canada, please review applicable provincial regulations.

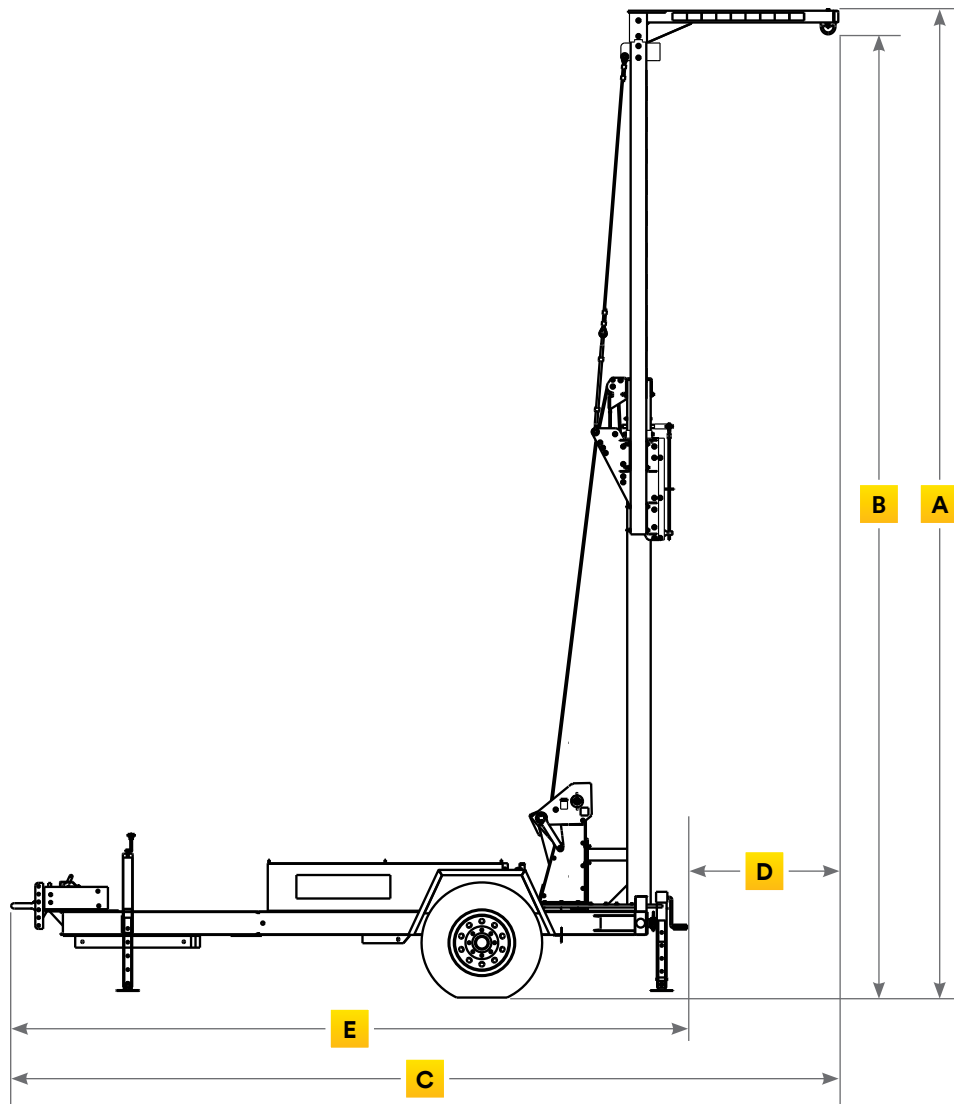

2-User Rated Trailer System									
SKU	Weight	Tongue Weight	"A" Overall Height	"B" Anchor Height	"C" Overall Length	"D" Cantilever from Trailer	"E" Trailer Length	"F" Trailer Width	OSHA SRL Rating
8530690	5,500 lbs (2495 kg)	550 lbs (250 kg)	13' 3"–21' 0" (4.0m–6.5m)	12' 9"–20' 6" (3.9m–6.3m)	17' 7" (5.4m)	3' (0.9m)	14' 5" (4.4m)	7' (2.1m)	≤ 1,350 lb. (6 kN) MAF & ≤ 900 lb. (4 kN) AAF

Accessories



8548000
Drive clutch enabling adjustment with a power drill.

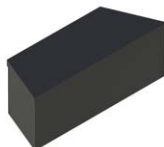

8530678
Job box mounts directly to trailer and can store tools and equipment.

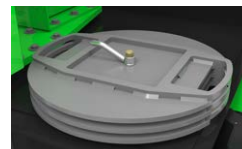

8548050
Stabilizing pads can add extra outrigger support on soft surfaces.



3M Fall Protection
3833 SALA Way
Red Wing, MN 55066 USA

Phone 800.328.6146
Email 3mfallprotection@mmm.com
Web 3M.com/FallProtection

Find complete product information at 3M.com/FallProtection.

3M, DBI-SALA and Flexiguard are trademarks of 3M.
Please recycle. Printed in USA.
© 3M 2022. All rights reserved. 70-0717-3968-7