

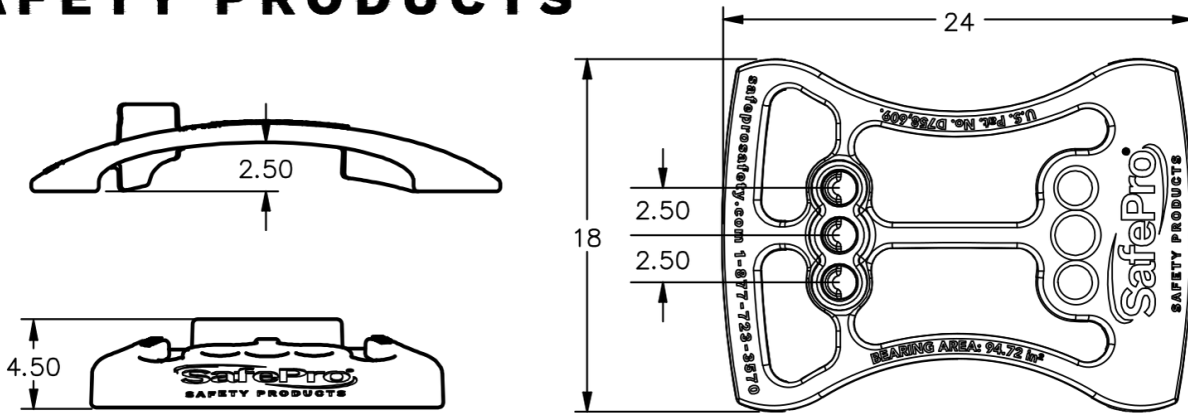

TECHNICAL DATA SHEET
BALLASTED GUARDRAIL BASE

SAFETY PRODUCTS



INFORMATION:

- THIS COUNTERWEIGHTED GUARDRAIL BASE HAS BEEN DESIGNED TO MEET OR EXCEED OSHA 1910 AND 1926 WHEN USED WITH COMPATIBLE RAIL.
- HOT DIP GALVANIZED FINISH PER ASTM A123

POST RECEIVER HOLES.
 (2) OUTER HOLES FOR
 1.66" OD SAFEPRO PANEL
 GUARDRAIL AND (1) INNER
 HOLE ACCOMMODATES
 UP TO 1.90" OD
 GUARDRAIL POSTS.

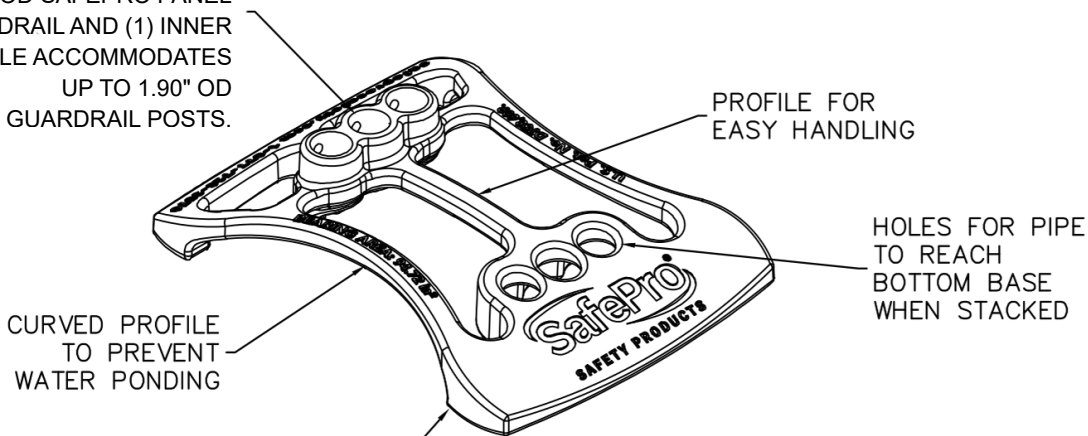

CURVED PROFILE
 TO PREVENT
 WATER PONDING

TAPERED SOFT
 EDGES PREVENT
 CUTS AND SNAGES
 ON ROOF MEMBRANE

PROFILE FOR
 EASY HANDLING

HOLES FOR PIPE
 TO REACH
 BOTTOM BASE
 WHEN STACKED

MATERIAL	CAST IRON
WEIGHT	84 ± 1 lbs.
FOOTPRINT	94.72 in ²
ROOF PRESSURE	0.9 psi

PROPRIETARY AND CONFIDENTIAL
 THE INFORMATION CONTAINED IN THIS DRAWING IS THE SOLE PROPERTY OF SAFEPRO SAFETY PRODUCTS.
 ANY REPRODUCTION IN PART OR AS A WHOLE WITHOUT WRITTEN PERMISSION OF SAFEPRO SAFETY PRODUCTS IS PROHIBITED.
 sales@safeprosafety.com (877) 723-3570 www.safeprosafety.com