

**MONORAIL TROLLEY**  
RATED FOR (1) EQUIPMENT OR (1) SAFETY LINE

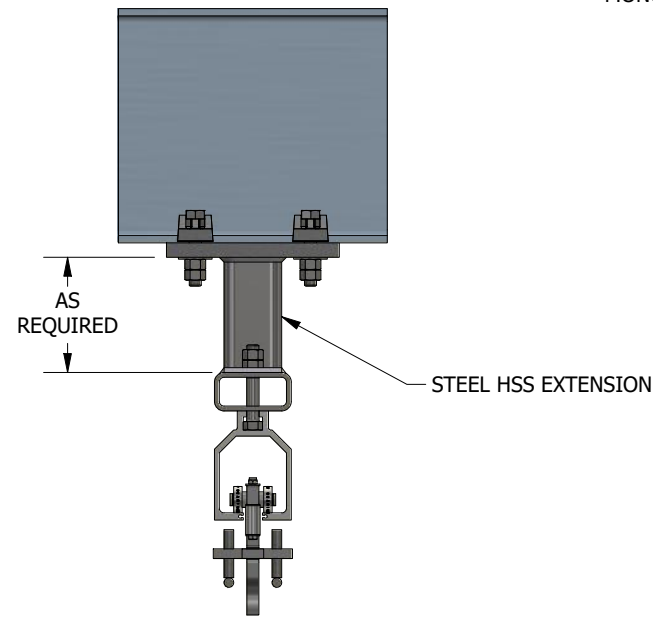

**WARNING:** FAILURE TO COMPLY WITH MANUFACTURER'S INSTALLATION PROCEDURES MAY RESULT IN PROPERTY DAMAGE, PERSONAL INJURY OR DEATH. ONLY QUALIFIED PERSONS EXPERIENCED IN THESE INSTALLATION METHODS SHALL INSTALL DIVERSIFIED FALL PROTECTION'S EQUIPMENT. IF METHOD OF INSTALLATION IS NOT UNDERSTOOD, DO NOT ATTEMPT TO INSTALL THIS EQUIPMENT.

**WARNING:** ALL DIVERSIFIED FALL PROTECTION'S FALL ARREST EQUIPMENT SHALL BE USED AS PART OF A COMPLETE FALL ARREST SYSTEM DESIGNED IN ACCORDANCE WITH ALL OSHA, ANSI, AND OTHER EQUIVALENT SAFETY STANDARDS. USER SHALL INSPECT ALL EQUIPMENT PRIOR TO EACH USE, INCLUDING ALL ATTACHMENT POINTS, LOCKS, AND PINS TO ENSURE ALL EQUIPMENT IS IN GOOD WORKING ORDER. ALL USERS SHALL BE PROPERLY TRAINED TO USE THE EQUIPMENT SAFELY AND PROPERLY TRAINED IN ALL OSHA, ANSI, AND OTHER SAFETY REGULATIONS WHEN USING THESE SYSTEMS. IF METHOD OF USE IS NOT UNDERSTOOD, DO NOT ATTEMPT TO USE THE EQUIPMENT. IMPROPER USE OF EQUIPMENT MAY RESULT IN PROPERTY DAMAGE, PERSONAL INJURY OR DEATH. ALL EQUIPMENT SHALL BE ANNUALLY INSPECTED BY A QUALIFIED PERSON AND RE-CERTIFIED AT PERIODS NOT TO EXCEED 10 YEARS UNDER THE DIRECT SUPERVISION OF A LICENSED PROFESSIONAL ENGINEER.

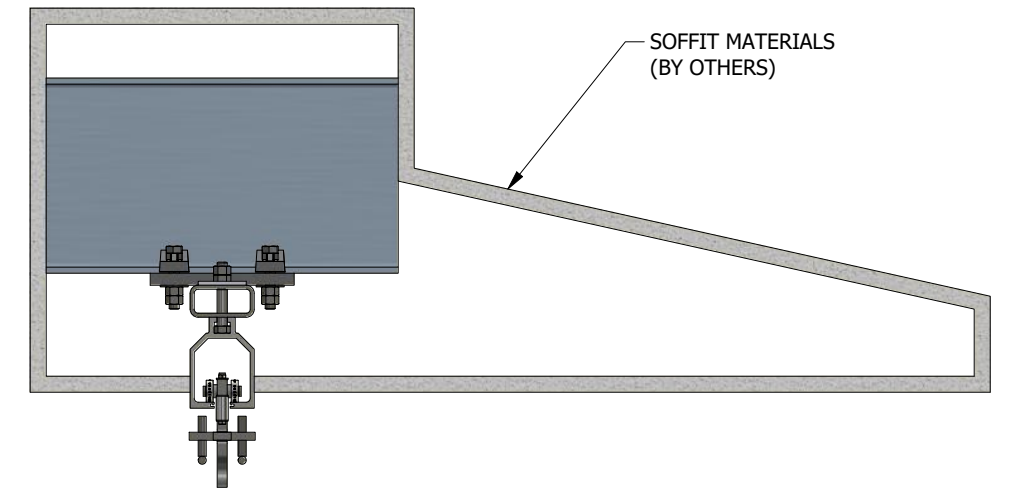
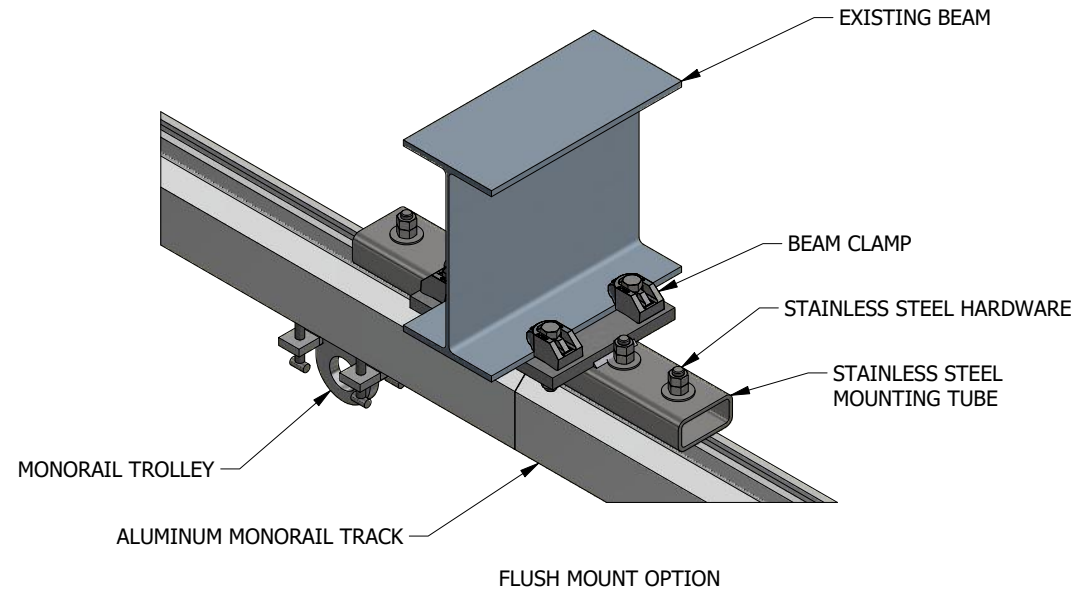
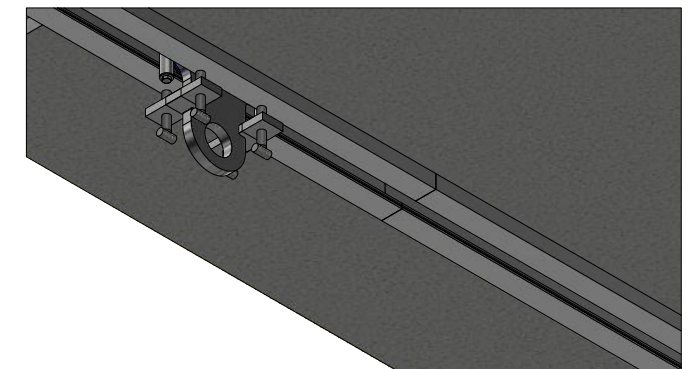

**SERIES NAME: MONORAIL ASSEMBLY**  
**SERIES NUMBER: MR-3000**

RATED LOAD: (1) EQUIPMENT & (1) SAFETY LINE, 1,250 lbs EA MAX  
FRACTURE LOAD: (1) EQUIPMENT & (1) SAFETY LINE, 5,000 lbs EA MAX

THESE DRAWINGS ARE THE PROPERTY OF DIVERSIFIED FALL PROTECTION AND SHALL NOT BE USED, COPIED, OR REPRODUCED WITHOUT WRITTEN PERMISSION.



ANCHORS@FALLPROTECT.COM

PH 866-387-9965

WWW.FALLPROTECT.COM